

Vacuum pump VRO 4/21

ZÁK. ČÍSLO: 2722 00 0000

The primary transport two-stage rotating oil vacuum pump is designed for pumping enclosed volume of 10^5 Pa by pumping rate of $4 \text{ m}^3 / \text{h}$. The possibility of using them is in the laboratory and industrial environments.

The intake air must not contain any mechanical impurities, aggressive gases and vapors and do not form with oil-filled explosive or aggressive mixture. Vacuum pump drives the single-phase motor, which forms with pump a compact pump unit.

Technické údaje

Number of stages	2
Pumping speed at preasure of 10^5 Pa and temperature of vacuum pump 55°C	$4 \text{ m}^3/\text{hod}$
Limit pressure of non-condensable gases with closed gas ballast	$< 1 \times 10^{-2} \text{ Pa}$
Ultimate vacuum with closed gas ballast (total pressure)	$< 1 \times 10^{-1} \text{ Pa}$
Ultimate vacuum with opened gas ballast (total pressure)	$< 2 \text{ Pa}$
Maximal partial pressure of pumping water vapors	$4 \times 10^3 \text{ Pa}$
Maximal outlet pressure	$1,5 \times 10^5 \text{ Pa}$
Tightness of the automatically closed valve at pressure differential 10^4 Pa	$10^{-1} \text{ Pa.l.s}^{-1}$
Minimal temperature for cold start	12°C
Maximal temperature of oil inside vacuum pump	60°C
Total leak rate of vacuum pump	$10^{-3} \text{ Pa.l.s}^{-1}$
Noise level with closed gas ballast and temperature of vacuum pump above 40°C	60 dB (A)
Coverage of device	IP 40
Outlet connection	KF 25

Inlet connection	KF 25
Recommended Oil	SN 56
Standard oil capacity (max/min)	500/250ml
Cooling of vacuum pump	Air
Voltage	230 V, 50 Hz
Motor power	250 W
Dimensions	501 x 150 x 237 mm
Weight	Cca 24 kg

Fotogalerie

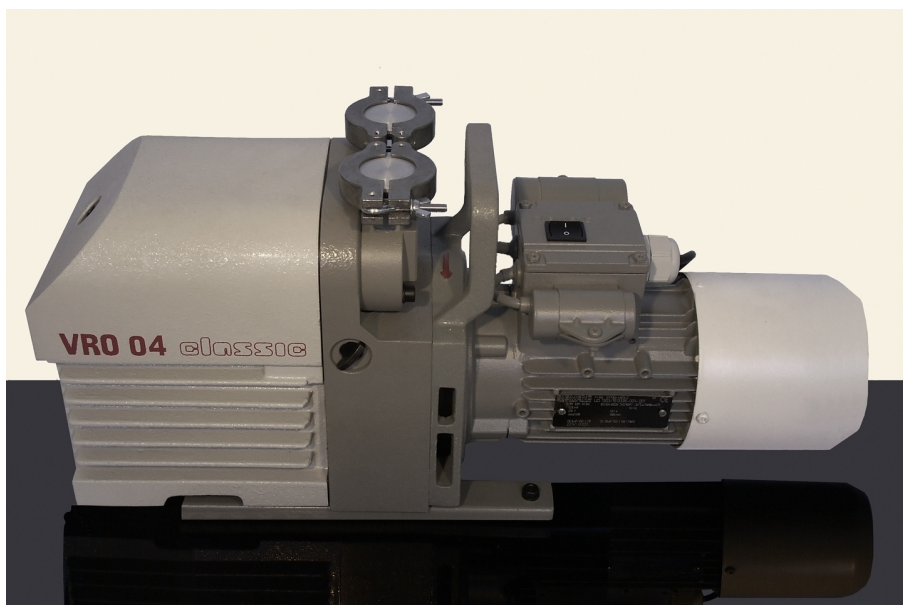

VÝVĚVA ROTAČNÍ OLEJOVÁ

VRO 04/11
VRO 04/13

VRO 04/21
VRO 04/23

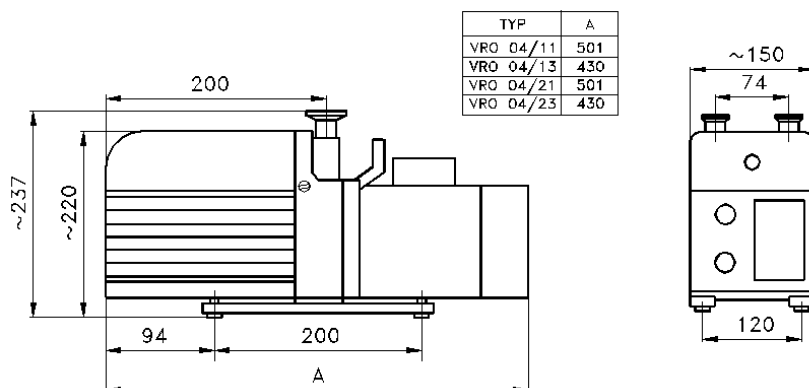

VRO 04-21 VRO 04-23

